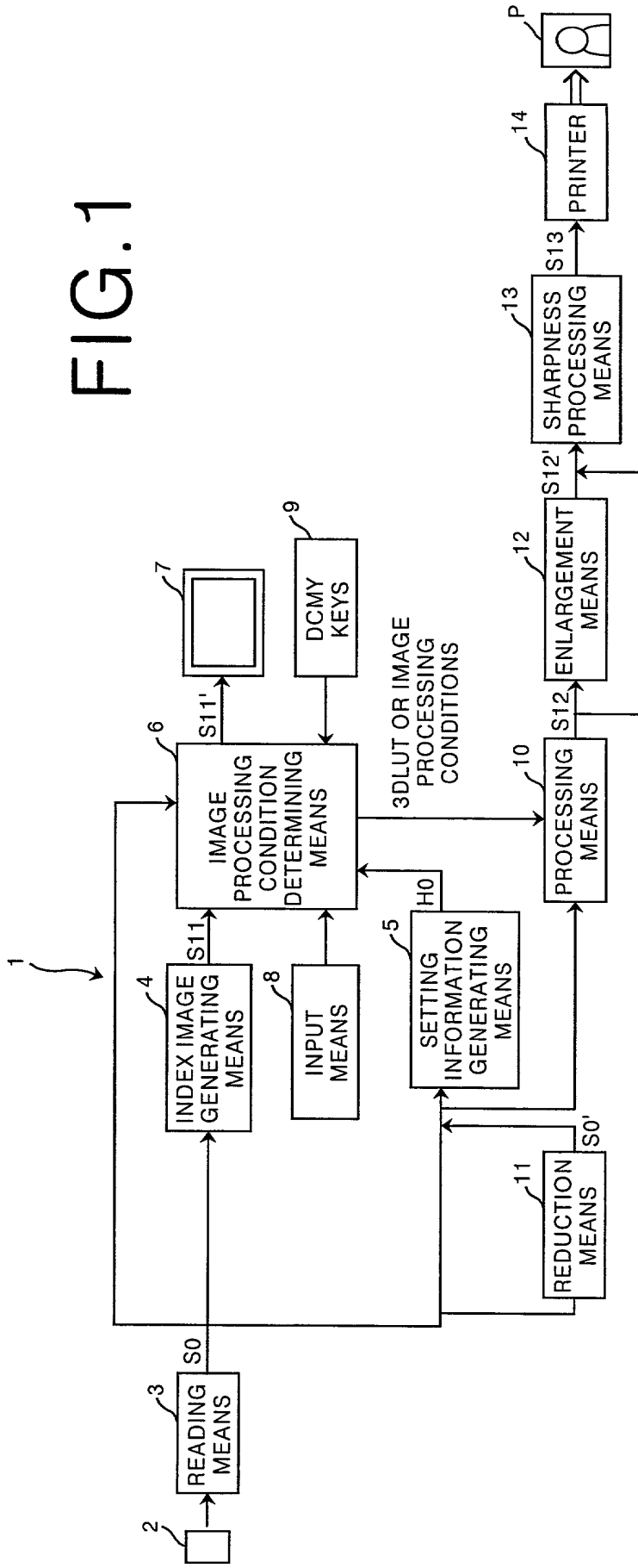

FIG. 1



6

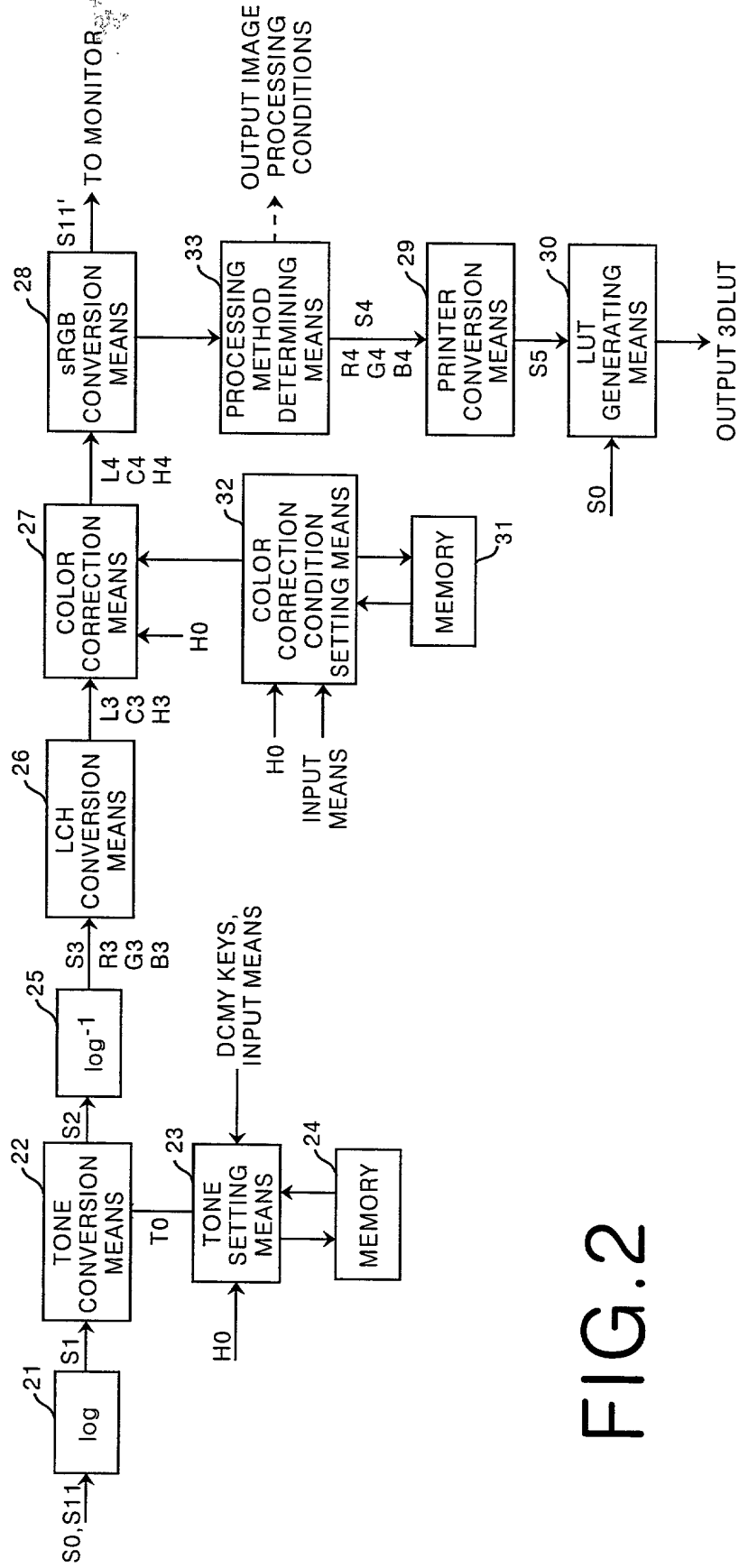
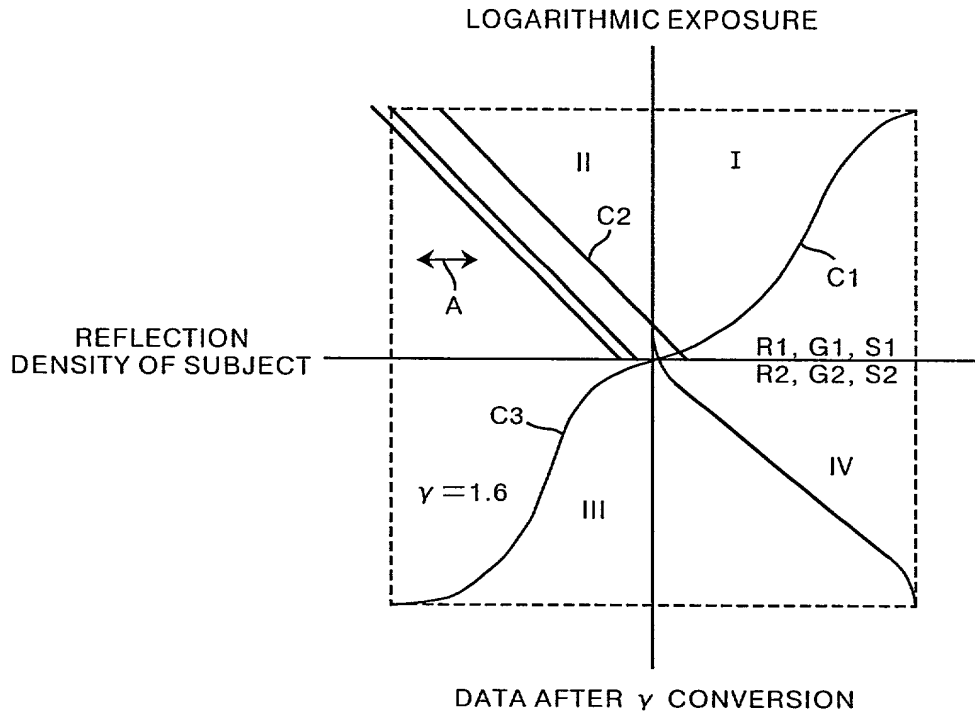

FIG. 2

FIG. 3



10/24/07 14:24:50

FIG.5

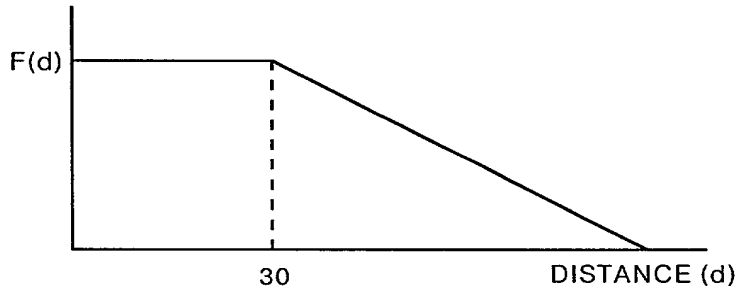

FIG.6

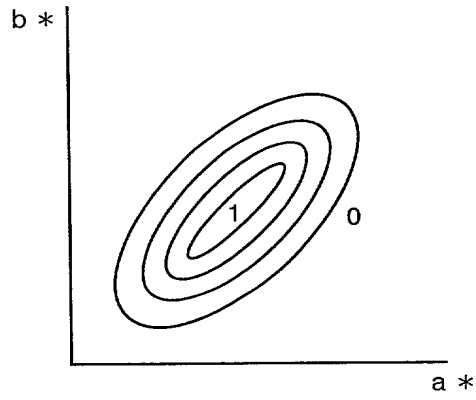
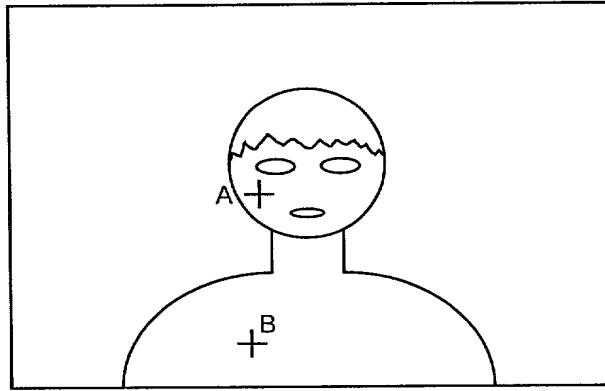

FIG. 7



TECHNOLOGICAL

FIG.8

POINT A	0	5	0
POINT B	0	-5	0

